



Master Grips

IT'S ALL IN YOUR HANDS

www.arri.com/ecs/mastergrips

ARRI 

ARRI MASTER GRIPS

Unprecedented fingertip control of camera and lens



ARRI Master Grips combine effective camera stabilization with comprehensive lens and camera control. Based on the classic ARRIFLEX handgrips trusted by generations of filmmakers, the Master Grips are aimed at ALEXA, AMIRA and third-party camera users who want flexible and responsive fingertip control while shooting handheld.

The Master Grips provide full control of focus, iris and zoom settings on cine lenses, and also offer a comfortable way to control the integrated servo motors of ENG and EF lenses. Camera control functionality includes REC and user button access for ARRI and third-party cameras.

With controls that are easy to reach and yet protected from accidental triggering, the Master Grips allow for prolonged handheld operating without any discomfort or strain. The integrated touchscreen makes setting up the Master Grips easy and boosts user confidence.

Versatile controls

- Full lens control
- Advanced camera control

Well-proven design

- Solid mechanical design
- Proven ergonomics

Easy to use

- Intuitive user interface
- Multi-lingual display

ARRI MASTER GRIPS

Intuitive user interface in a solid body



Master Grips are available in four versions: right-side and left-side, with either a rocker or a thumb wheel. The rocker enables super-smooth zooming, while the thumb wheel is perfect for iris or focus adjustments.



**Master Grip
Right Rocker MRR-1**
K2.0009493



**Master Grip
Left Wheel MLW-1**
K2.0009363



**Master Grip
Right Wheel MRW-1**
K2.0009494



**Master Grip
Left Rocker MLR-1**
K2.0009490

ARRI MASTER GRIPS – ACCESSORIES

Accessories



LCUBE CUB-2

Adapts servo zoom lenses (Hirose 12 pin) to LBUS (Lemo 4 pin). Enables Master Grips to directly control focus, iris and zoom of a servo zoom lens. Provides a switch to select between iris control from camera (auto-iris via camera Hirose 12 pin interface) or Master Grip.



Handgrip extensions

Stainless steel handgrip extension compatible with rosette-based systems, such as Master Grips. Available in three lengths (80 mm/160 mm/240 mm). Includes cable clips that facilitate cable management around Master Grips and lens motors.



Pan arm adapters

Compatible with most cine fluid heads, allowing Master Grips to be mounted on pan bars. Available for 18 mm or 20 mm pan bars, as well as with a universal clamp for up to 32 mm diameter pan bars.



Rod mounting adapter for AMIRA

Single rod bracket for 19 mm rods (15 mm rods with optional insert) mounting to AMIRA body (top-right). Optimized for camera stabilizer systems and lens motors. Compatible with original AMIRA handle and viewfinder bracket.



Master Grip case and cables

The sturdy, compact and purpose-designed case can safely hold a set of two Master Grips, three motors, handgrip extensions, LCUBE converters and cables. A set of new cables in dedicated lengths and with angled connectors provides optimized cabling solutions for the Master Grips.

For further information on Master Grip accessories please visit:
www.arri.com/ecs/mastergrips

ARRI MASTER GRIPS - SETUP SAMPLES

AMIRA / ALEXA Mini / Cine Lens

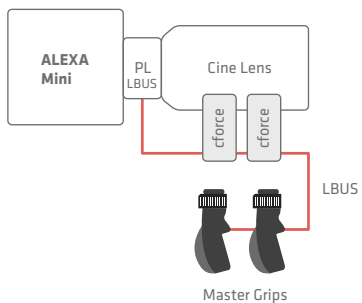
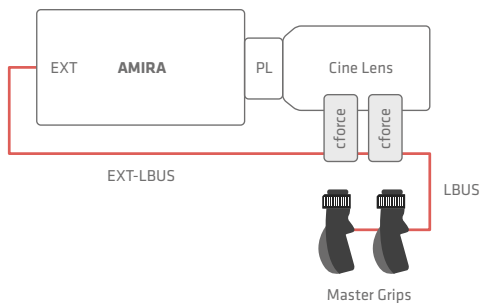

AMIRA / ALEXA Mini / Servo Zoom Lens*

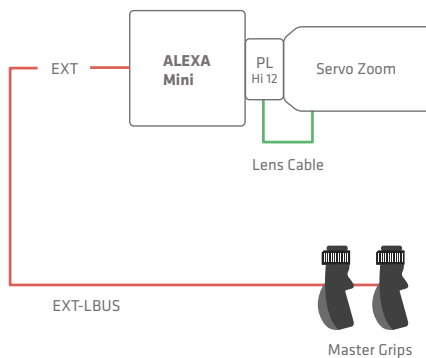
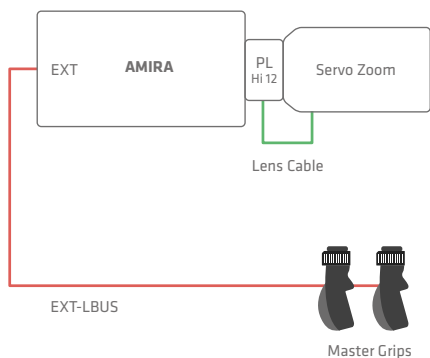

* Servo zoom control requires AMIRA/ALEXA Mini SUP 5.0

ARRI MASTER GRIPS - SETUP SAMPLES

AMIRA / ALEXA Mini / EF Lens*

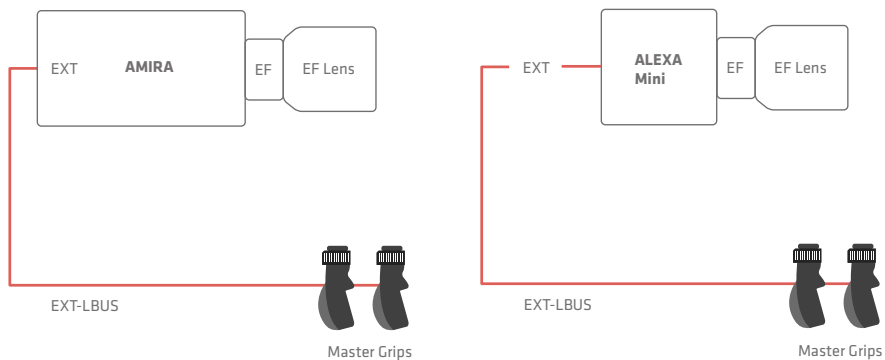

Third-Party Camera / Servo Zoom Lens

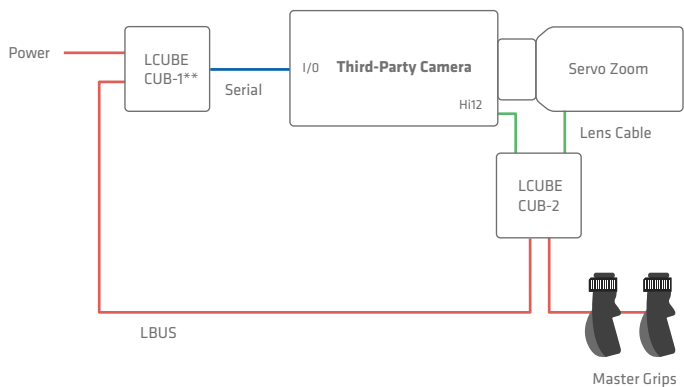

* EF lens control (initially iris only) requires AMIRA/ALEXA Mini SUP 5.0

** Sony/RED camera control requires CUB-1 SUP 2.0

ARRI MASTER GRIPS - SETUP SAMPLES

ALEXA Plus / ALEXA Mini / Cine Lens / Wireless Focus

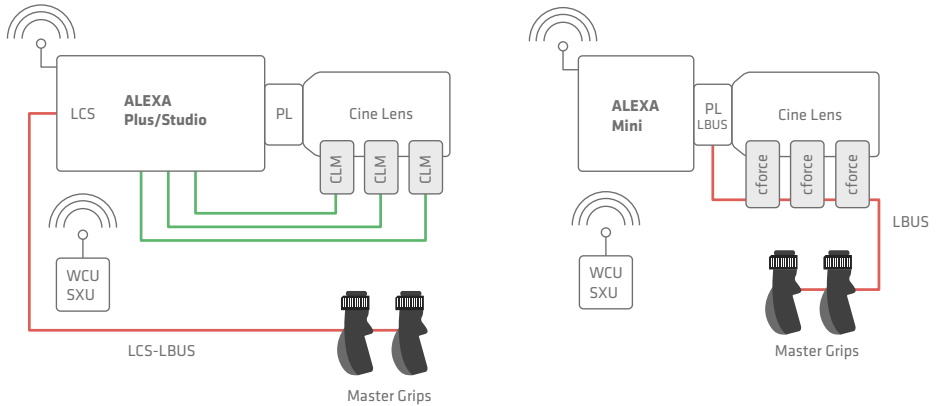

AMIRA in Multicam Setup* / Cine Lens

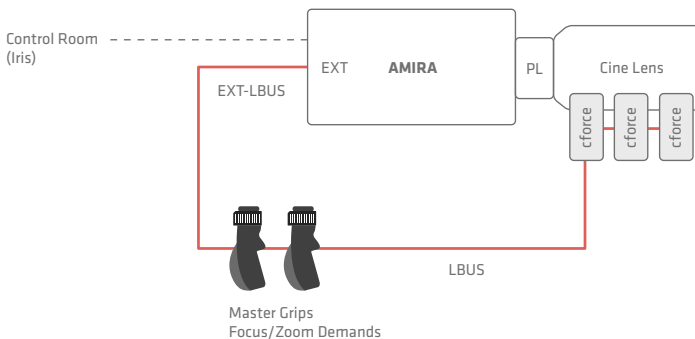

* Iris control via EXT requires AMIRA SUP 5.0

All sample setups are simplified drawings without any claim to completeness. Subject to change without notice.



Global Service and Support

ARRI products are renowned all over the world for their precision and durability. Nevertheless, ARRI values the trust of its customers in service and support as highly as their trust in the equipment itself. With service centers and support partners covering the entire globe, we are never too far away to provide the support you need, wherever you might be.

● ARRI subsidiaries

▮ Over 50 service and support partners worldwide; contact details at www.arri.com



Please contact your local dealer for more information
www.arri.com/goto/sales/camera